

9th International Conference on Axiomatic Design — ICAD 2015

## Low-cost spectrometer for Icelandic chemistry education

Gunnar Óli Sölvason<sup>a</sup>, Joseph Timothy Foley<sup>a,\*</sup>

<sup>a</sup>*Department of Science and Engineering, Reykjavík University, Menntavegur 1, Reykjavík 101, Iceland*

\* Corresponding author. Tel.: +354-599-6569; fax: +354-599-6201 E-mail address: [foley@ru.is](mailto:foley@ru.is)

### Abstract

Spectrometers are common analytical instruments in Chemistry. Ultraviolet-visible (UV-Vis) spectroscopy is the most commonly applied instrumental analysis technique being used at universities in the United States for the last three decades. Due to the popularity of spectroscopy and reduced budgets for undergraduate laboratories, there is great interest in low-cost, Do-It-Yourself spectrophotometers. This paper presents an implementation devised with axiomatic design principles for an affordable (sub \$1000) spectrometer. This design can be fabricated in a local Fab Lab using common off the shelf components and material to serve as a rigorous, analytical and teaching tool with a lifespan of at least 5 years. Due to a flaw in the concept of the optical path of the device, consistent measurements on absorption spectra could not be made comparable to a commercial equivalent. Even with this limitation, the device is still capable of serving its original purpose by measuring light source spectra and absorption of a selected wavelength to demonstrate Beer's law.

© 2015 The Authors. Published by Elsevier B.V. This is an open access article under the CC BY-NC-ND license (<http://creativecommons.org/licenses/by-nc-nd/4.0/>).

Peer-review under responsibility of the organizing committee of 9th International Conference on Axiomatic Design

**Keywords:** fab lab, spectrometer, chemistry education

### 1. Introduction

Spectrometers are instruments commonly used for instrumental analysis in Chemistry. They come in a variety of types and configurations, depending on their application, ranging dramatically in price based on their complexity. Prices range from a few hundred dollars up to tens of thousands. Ultraviolet-visible (UV-Vis) spectroscopy is the most commonly applied instrumental analysis technique being used at collage and undergraduate level in the United States, and has been for at least the last three decades [1,2].

### 2. Background

A visible spectrometer is a simple unit in terms of its fundamental principle. White light is broken into its components (spectra) using diffraction grating. The intensity of a specific wavelength of the spectra is then converted to a value directly proportional to the intensity of the light reaching a sensor.

Fundamentally, the idea behind the design of this device was to design an affordable spectrometer with the performance of a 5000 USD commercial unit, have the design be capable of being manufactured in a local Fab Lab and a basic workshop from easily obtainable materials and off the shelf components, while avoiding a black box feel for the end user. Fab Labs are

semi-standardized and exist internationally, making them a reasonable basic level for manufacturing capabilities [3]. The device described will be referred to as the AFL-Spectrometer or AFLS: "Affordable Fab Lab Spectrometer". In 2011 a group of students in the course "T-865-MADE Precision Machine Design" developed a low-cost spectrometer hereafter referred to as the MADE-Spectrometer [4]. Shortcomings in the design of the optical arm assembly limited its performance. While not a direct redesign of the MADE-Spectrometer, the AFL-Spectrometer can be considered a second iteration in the process of producing an affordable instrument for laboratory experiments in chemistry at Reykjavík University.

In the design of the AFL-Spectrometer, the systematical approach of axiomatic design was chosen to reach the highest quality design solution satisfying needs while minimizing resources utilized via iteration [5,6]. Results from the systematic process is what the inventor, Nam P. Suh, calls axiomatic design. This result is a structured description of how customer needs are systematically satisfied to end up with a design (be it a system, an artifact, or a computer program) that fulfills all the needs of the customer (that the designer has turned into Functional Requirements (FRs)), with the least amount of trial and error. In Suh's own words, "Axiomatic Design defines design as the mapping process from the functional domain to the physical domain, with the aim of satisfying the functional requirements specified by the designer" [7, page 26].

### 3. Development of requirements

When working inside the axiomatic design framework, the first task at hand is acquiring and describing the Customer Attributes (CAs). In the case of the AFL-Spectrometer, the customer is the faculty and the students that will use the device. Upon verbal communication with staff of the biochemistry and physics courses of the Reykjavík University, their desires became clear. What the customers wanted is an affordable, accurate, durable spectrometer working on the visible spectrum. Going deeper into examining those conversations, it became clear that the motivation is improving teaching capabilities, and the instrument is the means. Therefore, the CA is defined as:

CA<sub>0</sub> Teach students about Beer’s law and diffraction of electromagnetic waves on the UV-Visible spectra.

Leading to a top level FR and Design Parameters (DPs):

FR<sub>0</sub> Measure intensity of electromagnetic radiation for a selected wavelength.

DP<sub>0</sub> Low-cost measuring device for light intensities on the UV-Vis spectra.

We proceed to finding lower level FRs and corresponding DPs. This is done by decomposing and zig-zagging down the domains [8].

Not all of the information about the design is fit to become functional requirements. This information is, however, still relevant and needs to be kept track of. This information is preserved as Constraints (Cs), and presented in corresponding constraint tables. Other information includes optimization criteria presented in Table 4. More detail can be stored inside an expanded classical axiomatic design framework, *e.g.* requirements that are not functional in their nature, or Non-Functional Requirements (NFRs) [9]. NFRs were not used in this particular project and are therefore not discussed in detail.

Top level FRs along with their corresponding DPs are described in Table 1. Top level constraints can be seen in Table 2. Equation 1 is the top level design equation.

$$\begin{pmatrix} FR_1 \\ FR_2 \\ FR_3 \\ FR_4 \\ FR_5 \\ FR_6 \\ FR_7 \end{pmatrix} = \begin{bmatrix} X & 0 & 0 & 0 & 0 & 0 & 0 \\ X & X & 0 & 0 & 0 & 0 & 0 \\ 0 & 0 & X & 0 & 0 & 0 & 0 \\ 0 & 0 & 0 & X & 0 & 0 & 0 \\ 0 & 0 & X & 0 & X & 0 & 0 \\ X & 0 & 0 & 0 & 0 & X & 0 \\ X & 0 & 0 & 0 & 0 & 0 & X \end{bmatrix} \begin{pmatrix} DP_1 \\ DP_2 \\ DP_3 \\ DP_4 \\ DP_5 \\ DP_6 \\ DP_7 \end{pmatrix} \quad (1)$$

The top level design matrix is a triangular one and therefore decoupled. From the first column of the matrix it is evident that the electronic circuit assembly (DP<sub>1</sub>) must have an impact on more of the FRs than just FR<sub>1</sub>. Without the electronic circuit assembly FR<sub>2</sub>, FR<sub>6</sub> and FR<sub>7</sub> would be affected. Without the electronic circuit no electromagnetic radiation would be created since the light source would not be powered up, so FR<sub>2</sub> is affected. FR<sub>6</sub> is the measurement of light intensity. Without an electric circuit the sensor and micro-controller will not operate, therefore FR<sub>6</sub> cannot be fulfilled by its corresponding DP<sub>6</sub> without the electronic circuit assembly. In the same manner, no

Table 1. Top level FRs and corresponding DPs.

FR	DP
1 Supply power to components	Electronic circuit assembly
2 Generate electromagnetic radiation on visible spectrum	Light source
3 Collimate light from source	Collimating lens assembly
4 Pass light through constant sample material thickness	Sample holding assembly
5 Split light into measurable ordered spectra	Diffraction grating assembly
6 Measure light intensity	Light sensing assembly
7 Present data	Display assembly

Table 2. Top level constraints, not mapped to FRs

Constraints
1 Maximum price 1000 USD.
2 Manufacture in a Fab Lab (Laser cutter, 3D Printer).
3 Setup time less than 15 minutes.
4 Lifespan of a minimum 5 years.
5 Usable with outside light source.

data is presented on an LCD display without electricity. The only other non-diagonal element in the top level design matrix is the element corresponding to the effect the collimating lens assembly has on FR<sub>5</sub>. Without the collimating lens assembly the light can not be split into spectra, and therefore DP<sub>3</sub> affects FR<sub>5</sub>.

The second level design matrices can be found in Equations 2–3. For brevity any matrices that are purely diagonal are omitted. All the matrices can be represented in a combined, total design matrix represented as Figure 1. FR-DP mappings can be found in Tables 5–12. Second level constraints can be found in Table 3.

$$\begin{pmatrix} FR_{5,1} \\ FR_{5,2} \\ FR_{5,3} \end{pmatrix} = \begin{bmatrix} X & 0 & 0 \\ X & X & 0 \\ 0 & 0 & X \end{bmatrix} \begin{pmatrix} DP_{5,1} \\ DP_{5,2} \\ DP_{5,3} \end{pmatrix} \quad (2)$$

Table 3. Second level constraints, mapped to FRs

Constraints
4.1 Sample contained in a standard disposable cuvette.
6.1 Wavelength selection in 1 and 10 nm steps.
6.2 Must handle micro-stepping.
6.3 Must handle 2 A of current draw.

Table 4. Optimization criteria

2.1	Minimize drift
2.2	Minimize heat
2.3	Minimize energy use
4.1	Maximize repeatability
6.1	Minimize stray light reaching intensity measurement

Table 5. FR-DP mapping for power/electronics (FR1)

FR	DP	
1.1	Supply power to lights	Light power circuit
1.2	Supply power to CPU	Light source
1.3	Supply power to motor	Collimating lens assembly

Table 6. FR-DP mapping for light source (FR2)

FR	DP	
2.1	Provide white light	Super-bright, ultra-white LED
2.2	Provide calibration peaks at three known wavelengths of the spectra	Three color (RGB) LED
2.3	Allow light from an external light source in	Hole opening to the outside of structure

Table 7. FR-DP mapping for light collimation (FR3)

FR	DP	
3.1	Collimate light	Biconvex lens
3.2	Align collimator with light path axially	Lens bracket
3.3	Set distance between collimator and light source	Movement mechanism

Table 8. FR-DP mapping for sample (FR4)

FR	DP	
4.1	Keep length of light path through sample constant	Sample holder geometry
4.2	Keep sample at a fixed distance from collimator lens	Lens bracket

Table 9. FR-DP mapping for splitting light (FR5)

FR	DP	
5.1	Diffract collimated light at an angle	Diffraction grating sheet
5.2	Focus first order spectra onto a plane at a distance	Focusing lens assembly
5.3	Set distance between focusing assembly and sensor	Movement mechanism

Table 10. FR-DP mapping for (FR6)

FR	DP	
6.1	Select wavelength	Wavelength selector assembly
6.2	Narrow light reaching sensor from spectra to band	Narrow slit in front of sensor
6.3	Process data	Arduino Uno

$$\begin{Bmatrix} FR_{6.1} \\ FR_{6.2} \\ FR_{6.3} \end{Bmatrix} = \begin{bmatrix} X & 0 & 0 \\ X & X & 0 \\ X & 0 & X \end{bmatrix} \begin{Bmatrix} DP_{6.1} \\ DP_{6.2} \\ DP_{6.3} \end{Bmatrix} \quad (3)$$

$$\begin{Bmatrix} FR_{6.1.1} \\ FR_{6.1.2} \\ FR_{6.1.3} \\ FR_{6.1.4} \end{Bmatrix} = \begin{bmatrix} X & 0 & 0 & 0 \\ 0 & X & 0 & 0 \\ 0 & X & X & 0 \\ 0 & 0 & 0 & X \end{bmatrix} \begin{Bmatrix} DP_{6.1.1} \\ DP_{6.1.2} \\ DP_{6.1.3} \\ DP_{6.1.4} \end{Bmatrix} \quad (4)$$

#### 4. Implementation

With completion of the initial design process described in Chapter 3, the next step was to create a prototype spectrometer. The finished DSS SolidWorks™ CAD model can be seen in Figure 2.

Turning individual FRs into DPs requires designing physical parts that fulfill the purpose or function described by the FR.

Table 11. FRs for level 6.1 along with corresponding DPs.

FR	DP	
6.1.1	Set desired wavelength value	Rotary encoder
6.1.2	Control movement of motor	Motor controller
6.1.3	Move center of light sensor to selected wavelength	Stepper motor
6.1.4	Prohibit movement of motor outside of desired range	End stop sensor

Table 12. FR-DP mapping for data presentation (FR7)

FR	DP
7.1 Display data	LCD Display

		DPs																								
		1			2			3			4			5			6			7						
		1	2	3	1	2	3	1	2	3	1	2	3	1	2	3	1	2	3	1	2	3				
FRs	1	1	x																							
		2		x																						
		3			x																					
	2	1	x		x																					
		2	x			x																				
		3					x																			
	3	1					x																			
		2						x																		
		3							x																	
	4	1								x																
		2									x															
	5	1					x	x	x			x														
		2					x	x	x			x	x													
		3											x													
	6	1	1	x	x			x	x	x			x	x	x	x										
			2	x	x			x	x	x			x	x	x	x										
			3	x	x			x	x	x			x	x	x	x										
			4	x	x			x	x	x			x	x	x	x										
	7	1	x																							
		2																								
		3																								

Fig. 1. Total design matrix

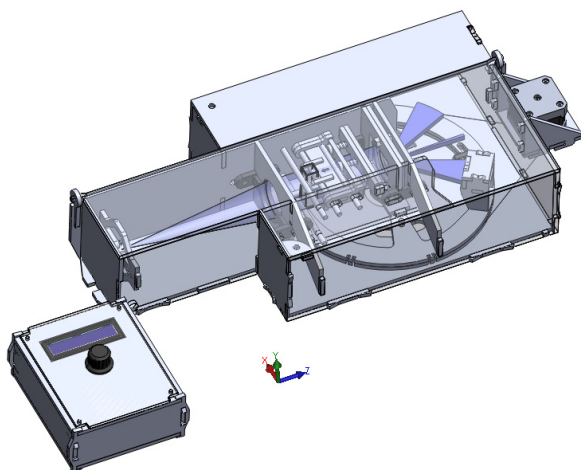

Fig. 2. CAD model of the AFL-Spectrometer. Most components are in the top enclosure. LED light sources are attached on the left. Possible light paths are represented as flat wedges. The stepper motor which moves the platform is visible on the right. The top lid has been made transparent to allow observation of the internal mechanisms. The rotating platform moves the light sensor. The small box on the left contains the control electronics and user interface.

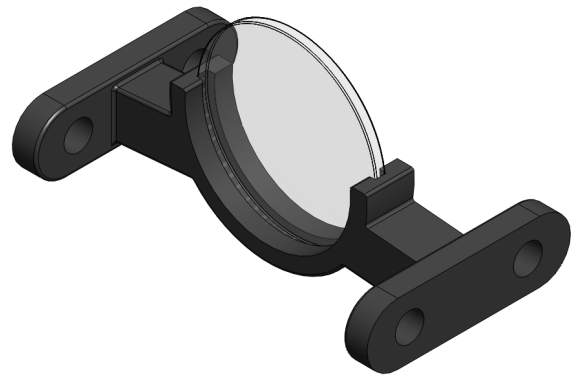

Fig. 3. CAD model of the lens holder assembly, designed to be 3D printed.

DPs should fulfill the FRs and nothing else. When all the FRs have been met, the design is complete. In the following section, particularly interesting DPs will be elaborated and their fulfillment of the FRs described.

4.1. DP3.2 Lens bracket

An important FR is described in (FR<sub>3.2</sub>, DP<sub>3.2</sub>): to align the collimator with the light path axially. As can be seen in Table 7 DP<sub>3.2</sub> is a lens bracket in the physical domain. Its purpose is to keep a biconvex collimating lens aligned with the light path (Figure 3).

4.2. DP4 Sample holder

The design matrix and examination of the light path make clear that it is critical how the sample will be held, due to its effect on the spectra alignment on the sensor (high information). Samples used in the AFL-Spectrometer will usually be liquid solutions in standard glass or plastic disposable cuvettes (12 × 12 × 45 mm) as described in C<sub>4.1</sub> in Table 3. It is clear that the sample holder needs to reliably and repeatedly fixture cuvettes.

For maximum repeatability, the center of mass of the cuvette was compared to the desired alignment translation axes ( $\vec{x}, \vec{y}, \vec{z}$ ) and rotational angles around those axes ( $\theta_x, \theta_y, \theta_z$ ). For an alignment reference,  $\vec{y}$  is normal to gravity and  $\vec{z}$  is the path of travel for the light. Critical movement directions are  $\theta_y, \theta_x, \vec{y}$  and  $\vec{x}$ .  $\theta_y$  and  $\theta_x$  result in elongation of the light path through the sample, while the other movements move the cuvette out of the path of light inside the device.

Traditional holding mechanisms use spring loaded coil spring or flexure “finger” mechanisms; a sample is inserted into an aperture to interface with the flexures. Some spectrometer models require the additional step of locking the sample in place to increase preload. Commercial units commonly use a plastic cassette for the cuvette that slid into a chamber with a stamped-metal flexure. We used a similar design but reduced the fixture to a minimum number of mechanical elements that would be easily manufactured in the Fab Lab.

Figure 4 shows the design concept of the sample holder. One spring-loaded shaft and four static shafts align the cuvette along the optically-flat sides. These contact areas ensure repeatable positioning of the sample focusing on eliminating movement

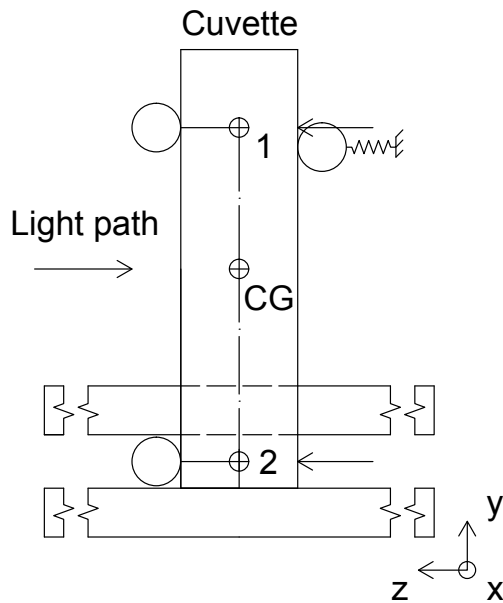

Fig. 4. Details of the cuvette holder design.

in the samples critical movement directions. Constraining only these four degrees of freedom only needs five shafts thus keeping the information content of the design to a minimum as per Axiom 2: adding more restraints would only add unnecessary complexity. A CAD rendering of the physical implementation of the concept in Figure 4 can be seen in Figure 5. The other directions are limited by laser-cut MDF features because they do not significantly affect the light path.

## 5. Results

This project should be considered from two viewpoints. First off, a design is developed where the end goal is to have the design of a mechanically functioning device that fulfills a set of physical requirements inside a boundary of constraints and optimization criteria. On the other hand, the constructed system based upon this design must perform as a measuring device. The design is complete when all FRs have been met as set up by the designer but the system is not complete until it can give measurements in the quality range defined in the requirements.

### 5.1. Physical mechanics

From an axiomatic standpoint, each FR in the project has a DP that satisfies it. Systematic evaluation was carried out for the FRs, their corresponding DPs, constraints and optimization criteria. This evaluation is omitted in this paper for brevity but can be found in [10].

### 5.2. Functioning system

To test the performance of the AFL-Spectrometers, measurements on two types of widely available sports drinks with distinct appearance were used, namely blue (berry & tropical flavor) and red (cherry flavor) Powerade™. Measurements were

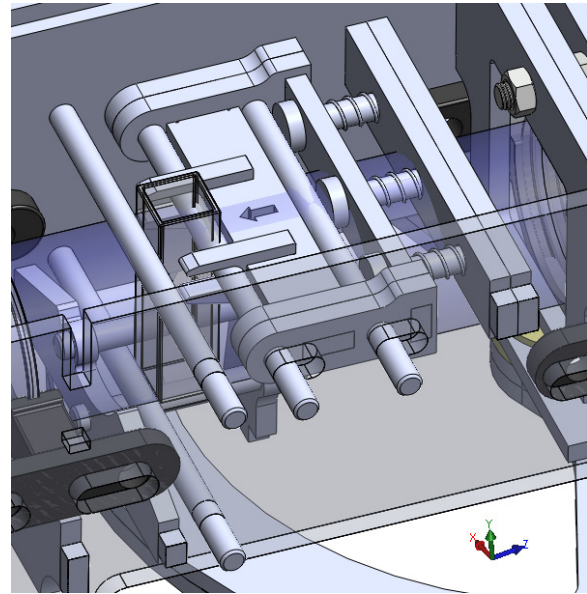

Fig. 5. CAD model closeup of the AFLS sample holder with cuvette inserted.

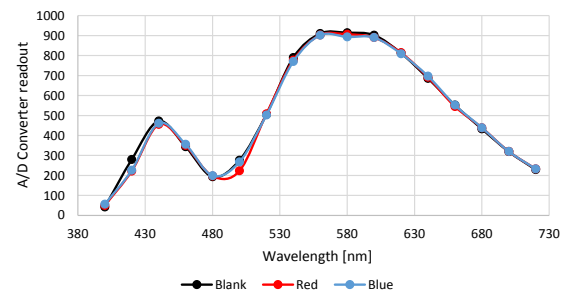

Fig. 6. Measurement without a sample compared to Powerade readings.

made using full volume disposable plastic cuvettes. Measurements showed that the device was not distinguishing a noticeable difference between blank spectra (produced by the light source) and the solutions being measured. This is shown in Figure 6. The device could, however, replicate the spectra of the light-source very well. This led to the discovery of a flaw in the concept of the device. The sample-holder was placed on the wrong side of the diffraction grating, and would therefore be unusable to produce the spectra of solutions. This was proven by doing a measurement using food dye to see how concentration would affect the sensor output, since it was known that measuring different concentrations at the peak wavelength of a solution should result in a linear increase in absorption. A set of reference solutions were created with food dyes water-filled cuvettes. The dilutions are annotated  $Dn$  where  $n$  is the number of drops of dye. These solutions were then measured in the sample-holder of the device as it had been designed (before the diffraction grating), then manually placed in front of the sensor (after the diffraction grating). Results from these measurements for the red food dye can be seen in Table 13. Figure 7 represents the results from Table 13 graphically. Similar results were realized for the blue food dye, but omitted for brevity.

Table 13. AFL-Spectrometer sensor raw readout for various concentrations of red food dye at 520 nm. Notation:  $D_n$  where  $n$  is the number of drops into a water-filled cuvette.

	Before grating	After grating
<b>Blank</b>	191	191
<b>Water</b>	190	140
<b>D1</b>	187	85
<b>D2</b>	184	52
<b>D3</b>	183	11
<b>D4</b>	179	7

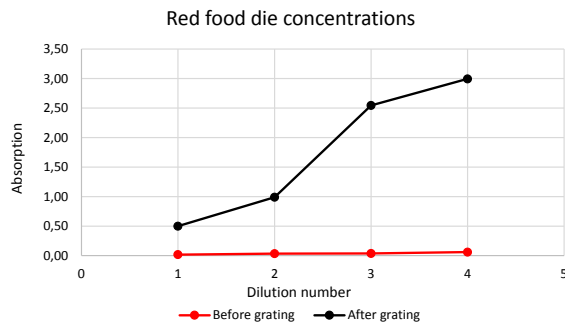

Fig. 7. Absorbance plot (Beer's graph) of red food dye data from Table 13.

As can be seen, no significant increase in absorption was realized with the sample in the designed sample-holder, while placing the sample behind it resulted in a fairly linear increase in absorbance values.

## 6. Conclusion

Results from this project should be considered with two aspects: reflecting on the success of the mechanical design and the system as a measuring device on the other.

It became clear that evaluation of the mechanical design would be very hard if no measurements had been made on the device. Measurements were performed to test the performance of the device, which led to the discovery of a flaw in the design concept.

Even though the capabilities were impacted by the location of the sample holder, the device fulfilled all the mechanical design requirements set up in the axiomatic design framework. Every FR had a DP satisfying it completely, the system was de-coupled, and therefore the design was completed in a satisfactory manner from an axiomatic standpoint. A more detailed analysis of what FR-DP mapping is inaccurate will be performed to better understand this problem.

Even though full spectra of solutions cannot be measured by the device in its current state, it still is capable of its top-level educational purpose. It can accurately measure the spectra of a light source. It can also be used to conduct experiments on Beer's law and thus serve students in both chemistry and physics. The only desired measurement it cannot produce is the absorption spectra of a solution. Pending another design

iteration, this may be corrected by moving the sample-holder behind the diffraction grating. It is expected that this would involve a redesign of the sample-holder and its position inside the device, since the sample would have to rotate to always be parallel to the sensor assembly.

The axiomatic design framework as a design foundation helped the designer discover many other flaws in the stage of zigzagging down the domains, realizing errors in the early stages of the design when they were cheap and easy to fix. That being said, it did not help in discovering this flaw in the concept, confirming that a design can never be better than the understanding of the designer: a design is only as good as the functional requirements.

What has been designed and realized can serve as a strong foundation for an accurate and affordable measuring device for physics and chemistry experiments in the undergraduate laboratory setting.

## Acknowledgments

Many thanks to Andrei Manolescu and Markéta Foley for their motivation and guidance from the RU chemistry and physics courses. We would also like to thank the class of T-865-MADE 2011 who developed the previous design [4]. We are very thankful to Svana Hafberg Stefánsdóttir who generously granted us access to spectrometers on behalf of the University of Iceland. Finally, we would like to thank Baldur Þorgilsson for his general guidance and ideas on how to approach the problem.

## References

- [1] Girard JE, Diamant CT. Instrumental analysis lecture and laboratory: A survey. *Journal of Chemical Education*. 2000;77(5):646–648.
- [2] Czegan DAC, Hoover DK. UV-Visible Spectrometers: Versatile Instruments across the Chemistry Curriculum. *Journal of Chemical Education*. 2012;89(3):304–309.
- [3] What is a Fab Lab? [homepage on the Internet]. Cambridge (MA): Fab Foundation; 2015 [cited 2015 Apr 22]. Available from: <http://www.fabfoundation.org/fab-labs/what-is-a-fab-lab/>.
- [4] Stefánsson AT, Steinarsdóttir EA, Björnsson GH, Stefánsson M, Ólafsson M, Hrafnisdóttir OK. Spectroscope; 2011. T-865-MADE Precision Machine Design Final Report. Available from: <http://afs.rnd.ru.is/course/T-865-MADE/2011/Projects/Spectrometer/Documentation/Report/report.pdf>.
- [5] Benavides EM. *Advanced engineering design - An integrated approach*. Woodhead Publishing; 2012.
- [6] Hundal MS. *Systematic Mechanical Design: a cost and management perspective*. New York, NY: ASME Press; 1997.
- [7] Suh NP. *The principles of Design*. Oxford University Press; 1990.
- [8] Suh NP. *Axiomatic Design - Advances and Applications*. Oxford University Press; 2001.
- [9] Thompson MK. Improving the requirements process in Axiomatic Design Theory. *CIRP Annals-Manufacturing Technology*. 2013;62(1):115–118.
- [10] Sölvason GO. *Low Cost Spectrometer for Icelandic Chemistry Education [Masters Thesis]*. Reykjavík University. Menntavegur 1, Reykjavík, Iceland; 2015. Available from: [http://afs.rnd.ru.is/dept/tvd/masters/gunnaros10/thesis/ruthesis/MSc\\_Solvason\\_Gunnar\\_2015.pdf](http://afs.rnd.ru.is/dept/tvd/masters/gunnaros10/thesis/ruthesis/MSc_Solvason_Gunnar_2015.pdf).